

# Safety Valves

## Type 50051.0011



Safety Valves, angle type, brass, type tested TÜV-SV.1009. S/G

Standard safety valve  
 with EPDM valve seal for vapours and gases  
 open bonnet, with lifting device  
 Outlet: female thread M15x1 with installed hose nozzle  
 Inlet: male thread type G (BSPP) acc. to ISO 228/1

**Part No. 50051.0011.0000**

Available options - on request only:

- hose nozzle acc. to customer specification
- body material CW509L

### Applications:

Provided as safety device for protection against excessive pressure in pressure vessels, especially for coffee machines.

Approved for non-toxic gases and vapours.

Working temperature: -10°C / +14°F (263K) up to +160°C / +320°F (433K)

For saturated steam use only up to 4 bar and +150°C / +302°F (423K)

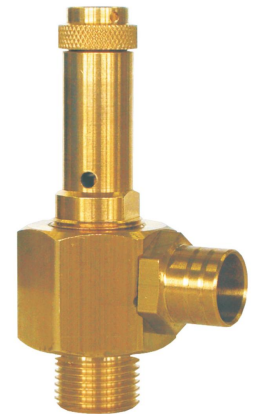

Materials	DIN EN	ASME/ASTM
1 Body	CW614N	B 249 UNS C38500
2 Disc	CW614N	B 249 UNS C38500
3 Valve seal	EPDM	
4 Stem	CW614N	B 249 UNS C38500
5 Bonnet	CW614N	B 249 UNS C38500
6 Spring	1.4571	A 313 Grade 316Ti
7 Lifting device	CW614N	B 249 UNS C38500
8 Closing cap	CC507L	B 36 UNS C26800
9 Hose nozzle	CW614N	B 249 UNS C38500

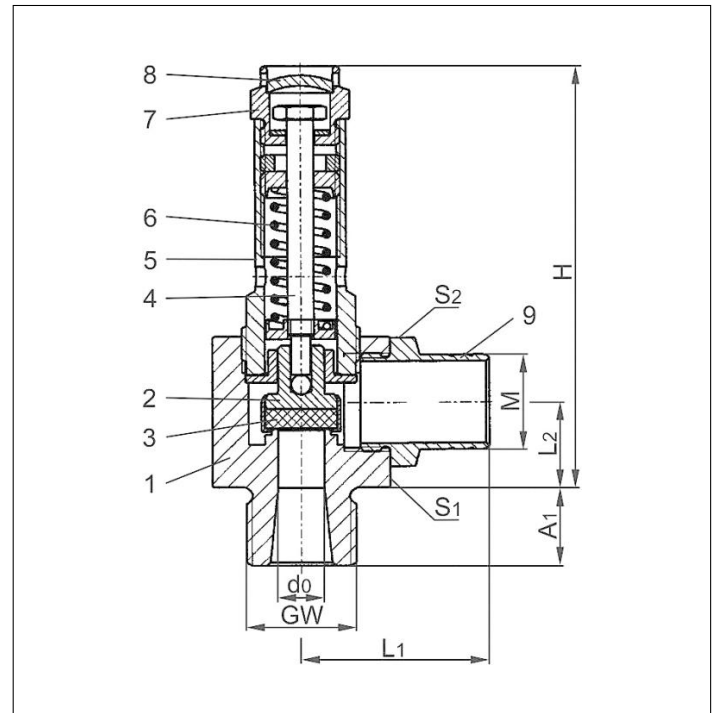

Type 50051.0011	Technical data	
Nominal size	<b>GW</b>	<b>3/8</b>
Orifice	d <sub>0</sub>	7
Set pressure range	bar	1.5-5.0
Hose nozzle-Ø	M	14.5
Height	H	64
Length	L <sub>1</sub>	28.5
Length	L <sub>2</sub>	13
Length	A <sub>1</sub>	12
Wrench size across flats	S <sub>1</sub>	27
Wrench size across flats	S <sub>2</sub>	17
Weight	ca. kg	0.16
Coeff. of discharge from 2.0 bar	α <sub>w</sub>	0.42

Dimensions in mm.

# Safety Valves

## Type 50051.0011



### Discharge capacities

Calculation of flow rate acc. to AD2000-Merkblatt A2

Medium:

**Air** in m<sup>3</sup>/h at 0°C and 1013.25 mbar

**Saturated steam** in kg/h

**The capacity indicated below is for a fully opened valve.**

$d_0$  - orifice

$A_0$  - flow area

Set pressure in bar (g)	GW	3/8	3/8
	$d_0$ (mm)	7.0	7.0
	$A_0$ (mm <sup>2</sup> )	38.48	38.48
	Medium	<b>Air</b>	<b>Saturated steam</b>
<b>1.5</b>		28	22
<b>2.0</b>		35	27
<b>2.5</b>		41	32
<b>3.0</b>		47	37
<b>3.5</b>		53	41
<b>4.0</b>		59	46
<b>4.5</b>		65	51
<b>5.0</b>		72	55