

Typ SK

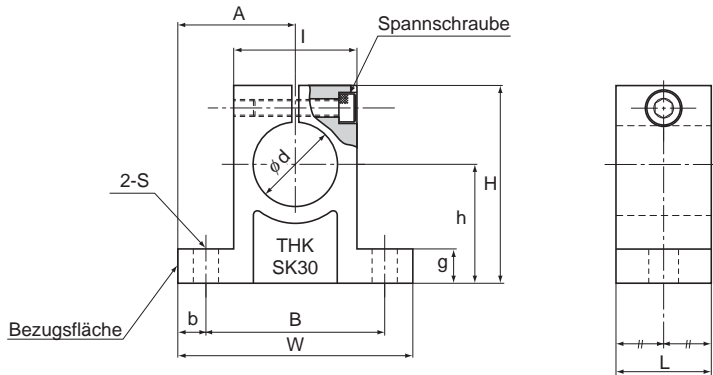

Einheit: mm

Typ	Hauptabmessungen														Gewicht g
	H	W	L	B	S	Befestigungs- schraube Typ nummer	h $\pm 0,02$	A $\pm 0,05$	b	g	l	Wellen- durch- messer d	Klemm- schraube Typ nummer		
SK 10	32,8	42	14	32	5,5	M5	20	21	5	6	18	10	M4	24	
SK 12	37,5	42	14	32	5,5	M5	23	21	5	6	20	12	M4	30	
SK 13	37,5	42	14	32	5,5	M5	23	21	5	6	20	13	M4	30	
SK 16	44	48	16	38	5,5	M5	27	24	5	8	25	16	M4	40	
SK 20	51	60	20	45	6,6	M6	31	30	7,5	10	30	20	M5	70	
SK 25	60	70	24	56	6,6	M6	35	35	7	12	38	25	M6	130	
SK 30	70	84	28	64	9	M8	42	42	10	12	44	30	M6	180	
SK 35	83	98	32	74	11	M10	50	49	12	15	50	35	M8	270	
SK 40	96	114	36	90	11	M10	60	57	12	15	60	40	M8	420	